



Quality certification :
1994: Certified to ISO 9002
1998: Certified to ISO 14001
2002: Certified to ISO 9001 (replacing ISO 9002)
2007: Certified to JIS MARK (JQA JIS B2312) (JQA JIS B2313)
2009: Certified to ISO 9001 : 2008

OEM/ODM SERVICE FOR :

- 1.High Purity Pipe, Valve and Pipe Fitting for Semiconductor, TFT-LCD and Solar Panel Industries.
- 2.High Purity Stainless Steel Bend and Pipe Formed Fittings.
- 3.High Purity Micro BW Fittings.
- 4.High Purity Face Seal Fittings.
- 5.High Purity UHP CGA/Diss Fittings.
- 6.Compression Fittings.
- 7.High Purity Ball Valves.
- 8.Manifold Pipe/Tube.
- 9.Diaphragm Valve and Valve Body.
- 10.EP, Electro-polishing Service & Ultra High Purity Cleaning and Packing.

Tachia Yung Ho Machine Industry Co.,Ltd.
UHP Components Business Division
Address:No 51, 39th Road, Taichung Industrial Park, Taichung City,Taiwan 407
Tel:886-4-36000080 Fax:886-4-36000081
<http://www.yhmco.com.tw>

大甲永和機械工業股份有限公司
潔淨級事業部
地址：台中市台中工業區39路51號
電話：886-4-36000080
傳真：886-4-36000081

2013.08





DAJA

DAJA-UHP-5-2.0

大甲永和機械工業股份有限公司
TACHIA YUNG HO MACHINE INDUSTRY CO., LTD.



UHP CGA/DISS Fittings Series

Description	Page
General Introduction	01
Materials of Construction	01
Features	01
Technical Specification	02
Product Codes	03
Nipple(10)	04
Nipple Product Table	05
 <ul style="list-style-type: none"> ■ Nipple(10) Butt-Weld type ■ Nipple(10) NPT type ■ Nipple(10) Face Seal type 	
Nut(20)	07
Nut Product Table	07
 <ul style="list-style-type: none"> ■ Nut(20) 	
Gasket(30)	07
Gasket Product Table	07
 <ul style="list-style-type: none"> ■ Gasket(30) 	
Outlet Plug(50)	07
Outlet Plug Product Table	07
 <ul style="list-style-type: none"> ■ Outlet Plug(50) 	

General Introduction

The design and proof-test confirms to UHP CGA V-1-2005, 12th edition.

Materials of Construction

Description		Material
Nut		304 stainless steel
Nipple Butt-Weld type		316L VAR/VIM+VAR
Nipple Face Seal type		316L/VAR
Nipple NPT type		316L
Outlet Plug With Ring & Chain	Toroid Piece	316L stainless steel
	Nut body, Screw	304
Outlet Cap		316L stainless steel
Gasket		Nickel 200 (35ft-lb)
		PCTFE (12ft-lb)
		Stainless Steel (30ft-1b)

Features

- 100% visual inspection in clean-room.
- Cleaned and packaged in a Class 100 clean-room environment.
- Leakage proof test at 1 x 10⁻⁹ atm. cc/sec.

Technical Specification

CGA Fittings Installation Instructions



1. Assemble the nipple with the nut, then butt-weld with the tube.



2. Install the diss gasket on the toroid of nipple.



3. Assemble the nut with the plug, then tighten slightly with fingers.



4. Please use the torque wrench to tighten the nut, and torque value of different gaskets can be set as below.

Material	Torque Value
Nickel 200	35 ft-lb
PCTFE	12 ft-lb
Stainless Steel	30 ft-lb

UHP CGA/DISS FITTINGS Product Codes

Product Series Code	Description	CGA Number		Connection Type	Size
10	Nipple	632	712	BW (Butt-Weld) VC (Face Seal Male) NP (NPT Male)	2 (1/4")
		634	714		
		636	716		
		638	718		
		640	720		
		642	722		
			724		
			726		
		728			
20	Nut	CGA Number		Material	
		6 (632-642)		S (304 Stainless Steel)	
		7 (712-728)			
30	Gasket	Material			
		N (Nickel)			
		P (PCTFE)			
		L (316L Stainless Steel)			
50	Outlet Plug	CGA Number		Material	
		63 (632-642)		Toroid Piece : 316 Nut body, Screw Pin : 304	
		71 (712-718)	72 (720-728)		

Nipple (10)



Nipple Butt-Weld

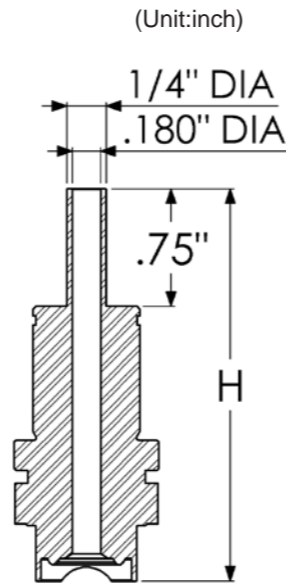

Nipple NPT Male

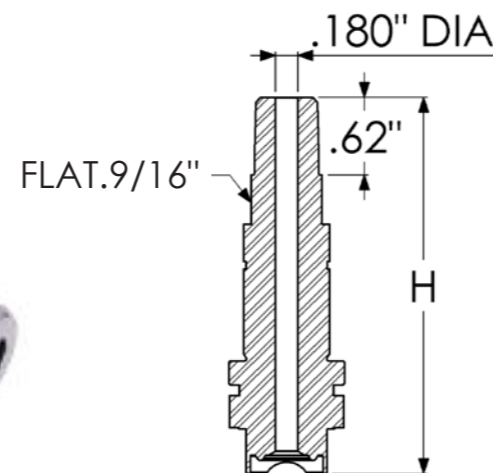

Nipple Face Seal Male

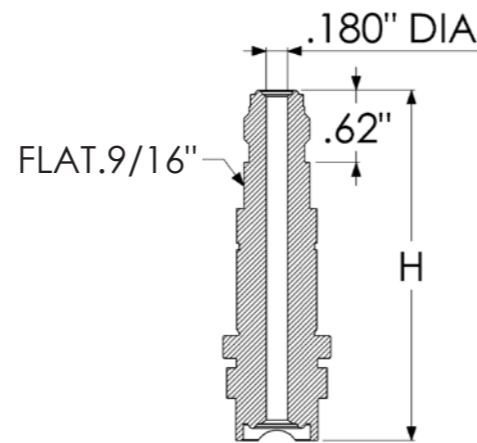

Nipple Product Table

CGA/DISS Number	End Connection	H Overall Length (inch)	Product Code
632	1/4" Butt-weld(BW)	2.50	10-632-BW-2
	1/4" Face Seal Male(VC)	3.00	10-632-VC-2
	1/4" NPT Male(NP)	3.00	10-632-NP-2
634	1/4" Butt-weld(BW)	2.50	10-634-BW-2
	1/4" Face Seal Male(VC)	3.00	10-634-VC-2
	1/4" NPT Male(NP)	3.00	10-634-NP-2
636	1/4" Butt-weld(BW)	2.50	10-636-BW-2
	1/4" Face Seal Male(VC)	3.00	10-636-VC-2
	1/4" NPT Male(NP)	3.00	10-636-NP-2
638	1/4" Butt-weld(BW)	2.50	10-638-BW-2
	1/4" Face Seal Male(VC)	3.00	10-638-VC-2
	1/4" NPT Male(NP)	3.00	10-638-NP-2
640	1/4" Butt-weld(BW)	2.50	10-640-BW-2
	1/4" Face Seal Male(VC)	3.00	10-640-VC-2
	1/4" NPT Male(NP)	3.00	10-640-NP-2
642	1/4" Butt-weld(BW)	2.50	10-642-BW-2
	1/4" Face Seal Male(VC)	3.00	10-642-VC-2
	1/4" NPT Male(NP)	3.00	10-642-NP-2
712	1/4" Butt-weld(BW)	2.50	10-712-BW-2
	1/4" Face Seal Male(VC)	3.00	10-712-VC-2
	1/4" NPT Male(NP)	3.00	10-712-NP-2
714	1/4" Butt-weld(BW)	2.50	10-714-BW-2
	1/4" Face Seal Male(VC)	3.00	10-714-VC-2
	1/4" NPT Male(NP)	3.00	10-714-NP-2

Nipple Product Table

CGA/DISS Number	End Connection	H Overall Length (inch)	Product Code
716	1/4" Butt-weld(BW)	2.50	10-716-BW-2
	1/4" Face Seal Male(VC)	3.00	10-716-VC-2
	1/4" NPT Male(NP)	3.00	10-716-NP-2
718	1/4" Butt-weld(BW)	2.50	10-718-BW-2
	1/4" Face Seal Male(VC)	3.00	10-718-VC-2
	1/4" NPT Male(NP)	3.00	10-718-NP-2
720	1/4" Butt-weld(BW)	2.50	10-720-BW-2
	1/4" Face Seal Male(VC)	3.00	10-720-VC-2
	1/4" NPT Male(NP)	3.00	10-720-NP-2
722	1/4" Butt-weld(BW)	2.50	10-722-BW-2
	1/4" Face Seal Male(VC)	3.00	10-722-VC-2
	1/4" NPT Male(NP)	3.00	10-722-NP-2
724	1/4" Butt-weld(BW)	2.50	10-724-BW-2
	1/4" Face Seal Male(VC)	3.00	10-724-VC-2
	1/4" NPT Male(NP)	3.00	10-724-NP-2
726	1/4" Butt-weld(BW)	2.50	10-726-BW-2
	1/4" Face Seal Male(VC)	3.00	10-726-VC-2
	1/4" NPT Male(NP)	3.00	10-726-NP-2
728	1/4" Butt-weld(BW)	2.50	10-728-BW-2
	1/4" Face Seal Male(VC)	3.00	10-728-VC-2
	1/4" NPT Male(NP)	3.00	10-728-NP-2

Nut(20)

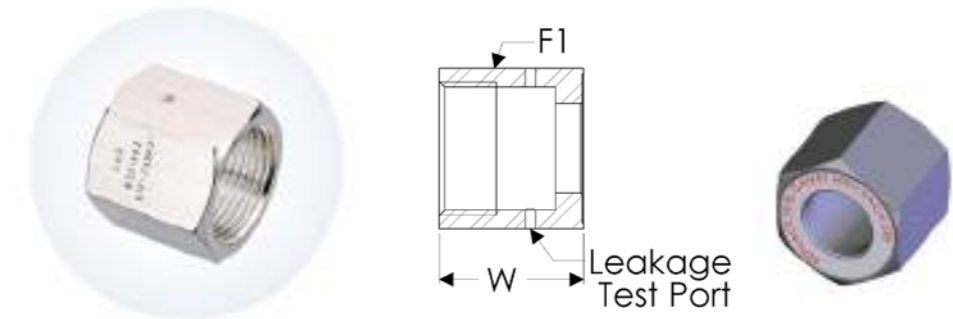

Nut Product Table

CGA/DISS Number	F1 Hex Flat	W	Product code	Material
632 - 642	1-1/4"	1.13"	20-6-S	Stainless Steel 304
712 - 728	1-3/8"	1.13"	20-7-S	Stainless Steel 304

Gasket(30)



Gasket Product Table

Material	A	H	E	Product Code
Nickel 200	.56"	.105"	.21"	30 N
PCTFE	.56"	.125"	.21"	30 P
Stainless Steel 316L	.56"	.105"	.21"	30 L

Outlet Plug(50)

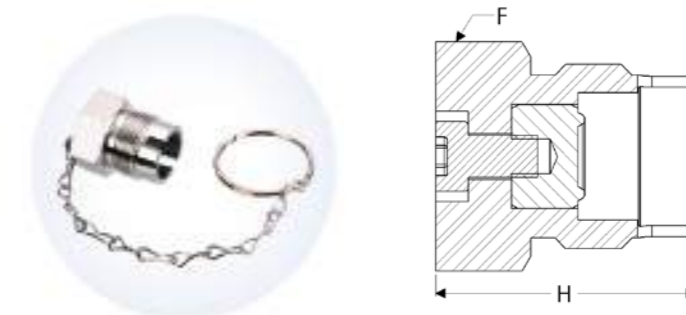

Outlet Plug Product Table

CGA/DISS Number	End Connection	H	F	Product Code
632-642	Blank Plug	1.53"	1-1/8"	50-63-S
712-718	Blank Plug	1.53"	1-1/4"	50-71-S
720-728	Blank Plug	1.53"	1-1/4"	50-72-S

MEMO

A series of horizontal dashed lines for writing a memo.



High Purity Pipes & Pipe Fittings



Micro Butt-Welding Fittings



Iok-DJ® Compression Fittings



Metal Gasket Face Seal Fittings



Diaphragm Valve & Ball Valve



UHP CGA/DISS Fittings Series

