

Pressure regulator U13



Line pressure regulator
U13 P-200-16-0-M-M-0-NFG



Manifold pressure regulator
U13 M-200-20-M24f-M-M-0-O2

Product features

- Diaphragm pressure regulator
- For non-corrosive industrial gases
- Single-stage with high control accuracy
- Central filter in the pressure regulator
- Safety pressure gauge acc. to DIN ISO 5171
- Pressure regulator with integrated relief valve
- Pressure regulator for oxygen with filter in inlet fitting
- Accessories like wall brackets and in-/outlet fittings are also available

Attention:

For the pressure regulator U13 special outlet fittings with orifice holes have to be used to ensure a correct function of the regulator.
see: data sheet "Fittings"

P „Performance“ for precise regulation

M „Medium“ for medium performance

F „Flow“ for high flow rates

Technical data

Type	single-stage
Flow rate Q	max. 500 m ³ /h
Inlet pressure P₁	max. 40 /200 /300 bar
Outlet pressure P₂	see table below
at P ₁ = 40 bar:	max. 1,5 ... 4 bar
at P ₁ = 300 bar:	max. 6 ... 35 ¹⁾ bar

¹⁾ for oxygen up to 30 bar available!

Materials

Body:	brass
Bonnet:	Alu, powder coated
Valve seat:	PA
Diaphragm:	NBR

In- and outlets

Inlet:	G ½" female M24 x 1,5 (oxygen)
Outlet:	G ½" female
Pressure gauge ports:	G 1/4" female
Outlet relief valve:	G 3/8" male

Temperature range -30°C to +60°C

Leak rate <10⁻³ mbar l/s He

Weight ca. 4.2 kg

Performance factors and outlet pressures to find the flow rates of the pressure regulators U13

U13 series		max. P ₂ : 1,5 ... 16 bar			max. P ₂ : 20 / 30 / 35 bar		
Type		P	M	F	P	M	F
Performance factor for P ₁ = 300 bar (40 bar)	L ₅ (5% pressure drop)	4,5 (4)	5 (4,5)	5,5 (5)	4,5	5	5,5
	L ₁₀ (10% pressure drop)	6 (5,5)	6,5 (6)	7 (6,5)	6	6,5	7
	L _{max}	7,5 (7)	8 (7,5)	8,5 (8)	7,5	8	8,5
max. outlet pressure P ₂ [bar]	at 40 bar inlet pressure	4	4	4	-	-	-
	at 200 bar inlet pressure	16	16	16	35	35	35
	at 300 bar inlet pressure	16	16	16	35	35	35
Outlet pressure variations [%] relating to inlet pressure variation		1	1,85	2,7	1,25	2,2	3,5

Pressure regulator U13



Dimensions and connections

Dimensions (front- and side view)

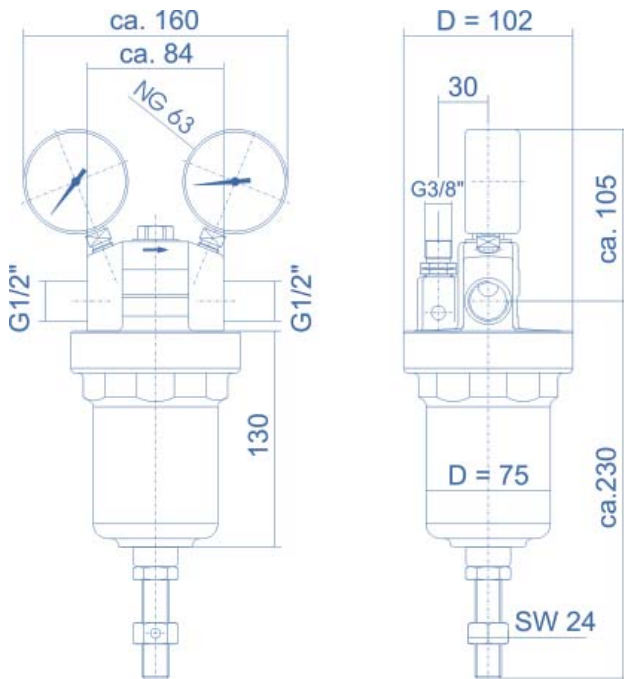

Dimensions with **wall bracket 512.07600**
(as accessory available)

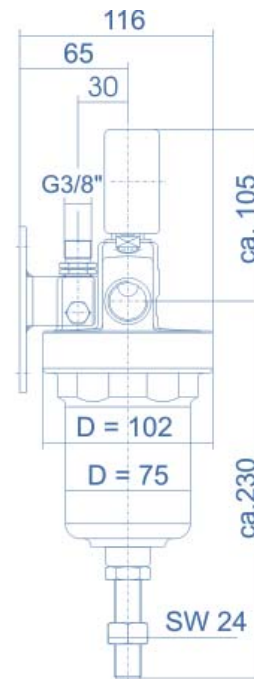

Ordering information: Pressure regulator U13

U13 P - 300 - 10 - 0 - M - M - 0 - NFG

In- and outlet-fittings:
see data sheet "Fittings"

Type

See table "Performance factors..."
on page 1

Inlet pressure P_1

10	max. 10 bar
20	max. 20 bar
25	max. 25 bar
40	max. 40 bar
50	max. 50 bar
100	max. 100 bar
200	max. 200 bar
300	max. 300 bar

Type of gas

NFG	non flammable gases
FG	flammable gases
O2	oxygen

Outlet pressure P_2

1,5	max. 1,5 bar
2,5	max. 2,5 bar
4	max. 4 bar
6	max. 6 bar
10	max. 10 bar
16	max. 16 bar
20	max. 20 bar
30	max. 30 bar
35	max. 35 bar